

# TRIKKE™

ELECTRIC VEHICLES

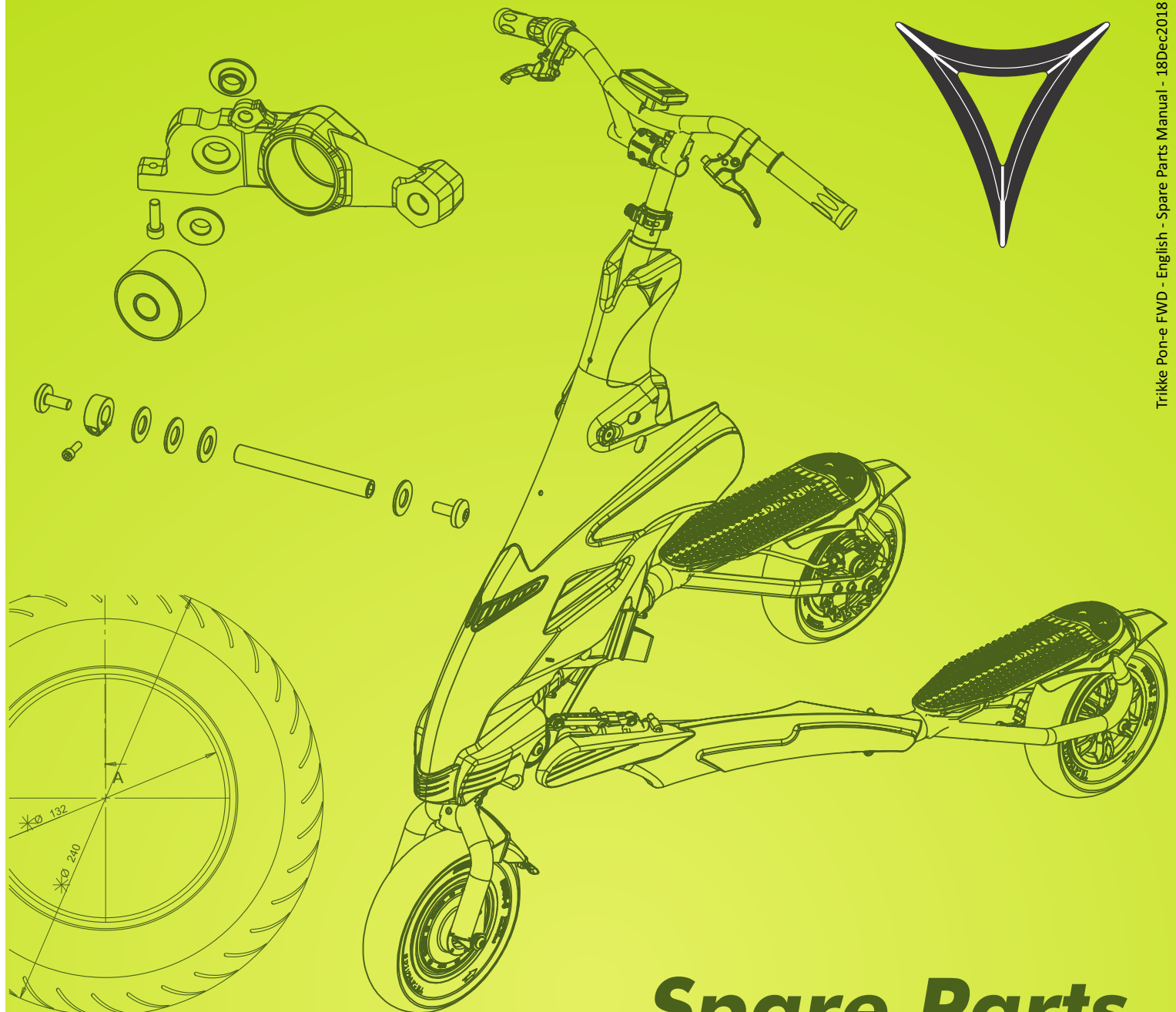

Trikke Pon-e FWD - English - Spare Parts Manual - 18Dec2018



## Spare Parts Manual

THIS MANUAL REFERS TO MODELS:  
FWD (front wheel drive)

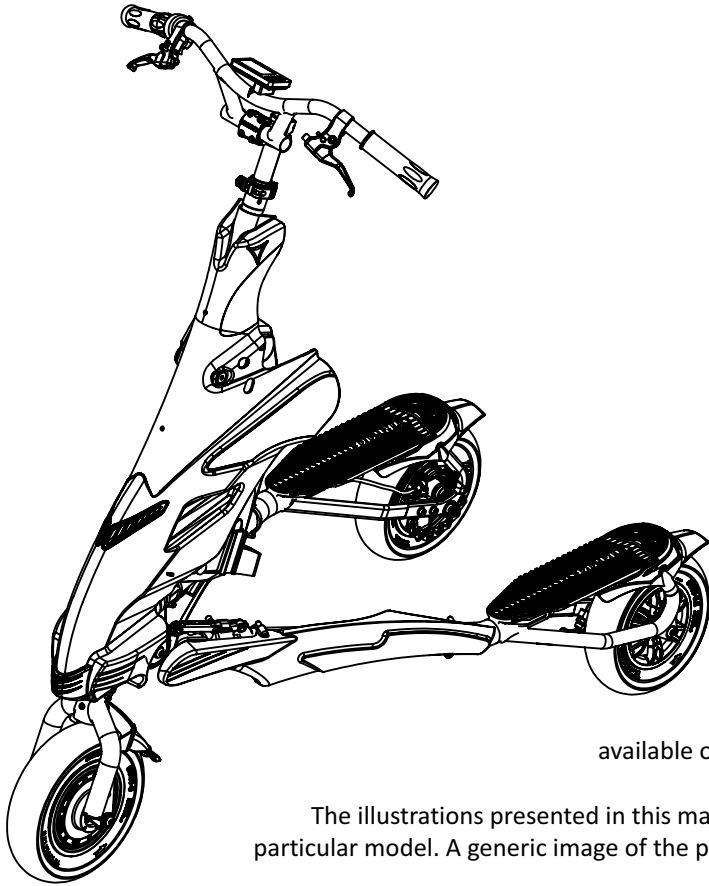

## About the Replacement Parts Manual

This manual identifies and lists all the commercial replacement parts available for the Trikke Tribred Pon-e models available by the date of issue.

The information contained in this document allows the customer or service center to obtain a commercial part number and order the correct replacement part for the vehicle.

Assemblies are broken down by groups. The exploded views will help to locate individual parts within the assembly, showing how they are grouped and available for sale.

It's important to keep the manual up to date. New revisions will be issued with time and subscribers will be notified about the revisions and a brief summary. The most updated version of this manual is also available online for download.

The illustrations presented in this manual may be slightly different from the actual part in a particular model. A generic image of the part is used for identification purpose.

## How To Locate a Part

The parts are presented within a function group. Once the part is located on the explode view, the part number, part name, qty per vehicle, and versions can be identified on the list below the image. Always pay attention to the vehicle model, version and year, which can be identified by the serial number.

- **Brake Group** - page 2
- **Cambering Group** - page 4
- **Folding Group** - page 5
- **Frame Group** - page 6
- **Wheel Group** - page 7
- **Electric Group** - page 8
- **Steering Group** - page 10
- **Trim Group** - page 12

Group: **BRAKE (B)**

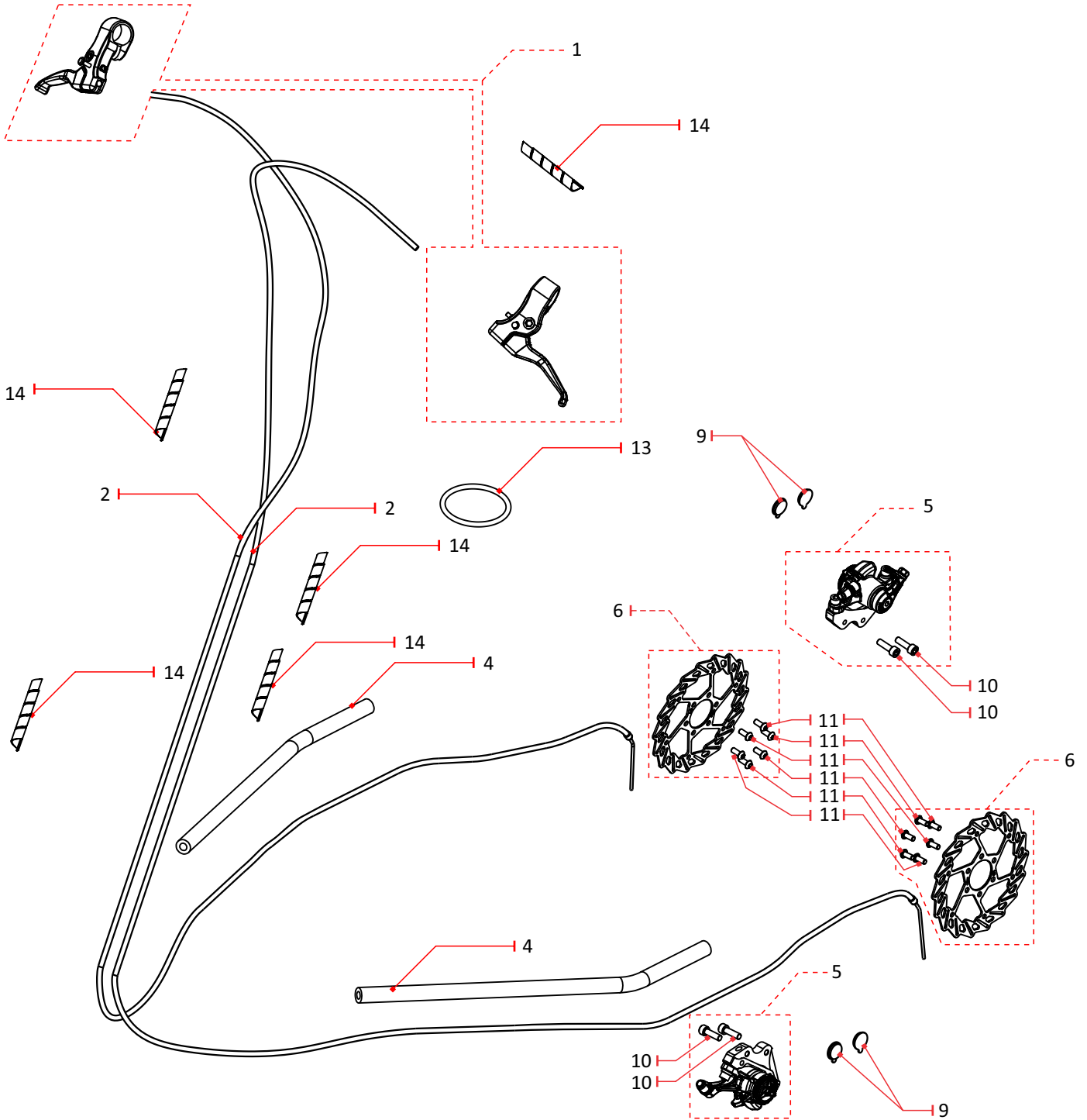

## Group: BRAKE (B)

ITEM	PART #	PART NAME	QTY*	NOTE
1	C-9C15/C-9C11	BRAKE LEVER PAIR w/ lock DISC	01	Promax LK-162AP w/lock
2	S-0C23 - A/S-0C43 -A	BRAKE CABLE SET, PAIR	01	cables with housings
4	P-0871	CUSHION, ARM BRAKE CABLE	02	
5	C-0C67/S-0808	BRAKE CALIPER SET, DISC rear	02	with bolts M6 x 20
6	P-0T171 - A/C-0105	BRAKE ROTOR SET, DISC rear	02	diam 140mm (with 6 bolts) -rear
9	C-0C68	PAD SET, BRAKE T8h	02	disc brake pads (pair is for one caliper)
10	S-0808	BOLT, M6 x 20 x 10 (DIN 912)	04	M6 x 20 x 10 (rear)
11	C-0105	BOLT, DISC BRAKE	12	M5 x 12 hex4 pan head (rear)
13	C-0C69	O'RING, FRONT CABLES (50 x 4)	01	
14	C-0C42	WRAP, SPIRAL CABLE	05	

\*Quantity needed to 1 brake set.

## Group: CAMBERING (C)

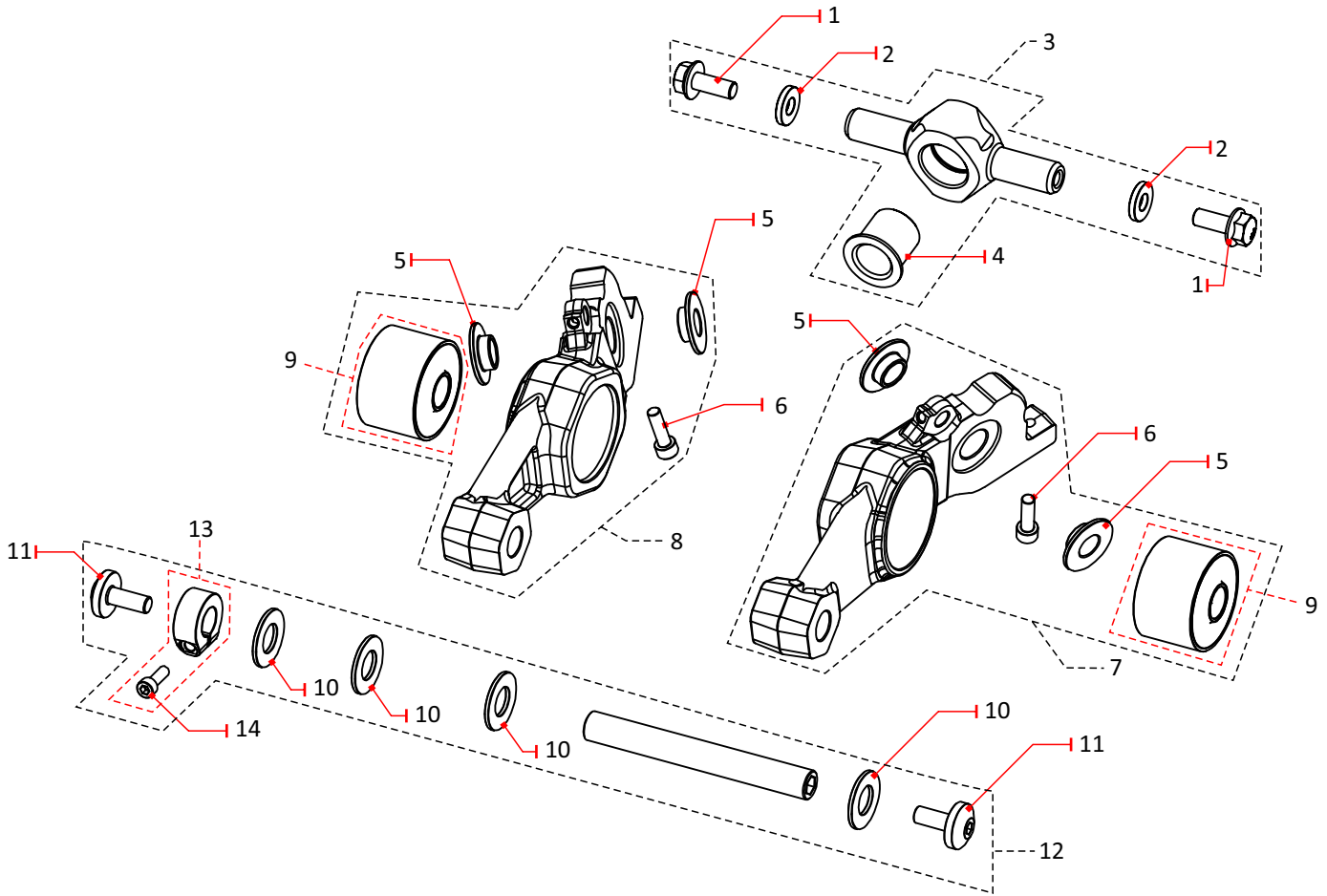

ITEM	PART #	PART NAME	QTY*	NOTE
1	S-0T28-A	BOLT, YOKE	02	FLANGE BOLT, M8 x 20 x 18 (DIN 6921)
2	S-0T151	WASHER, YOKE BOLT	02	Ø8.1 x Ø18.5 x 3
3	P-0H03-B/P-0T15-A/S-0T28/S-0T151	YOKE SET	01	with 1 bushing, 2 bolts and 2 washers
4	P-0T15-A	BUSHING, YOKE	01	1 piece
5	P-0012	BUSHING, FOLDING	04	
6	S-0808	BOLT, M6 x 20 x 10 (DIN 912)	02	M6 x 20mm
7	P-0C40-B/P-0012/C-0C13/S-0808/P-9C230	EXTENSION SET, LH ARM	01	with 1 PU bushing, 2bushings, 1 bolt, 1 nut
8	P-0C39-B/P-0012/C-0C13/S-0808/P-9C230	EXTENSION SET, RH ARM	01	with 1 PU bushing, 2bushings, 1 bolt, 1 nut
9	P-9C230	PU BUSHING	02	
10	P-0C14-A	SHIM, MAIN AXLE	04	Ø28 x 2t x Ø14
11	S-0C06	BOLT, MAIN AXLE	02	M8 x 20mm hex5
12	S-0C01/S-0C06/P-0C14/P-9116-e	AXLE SET, MAIN	01	with 1 Clamp, 3bolts, 4 washers
13	P-0116-e/S-0108-e	CLAMP SET, MAIN AXLE	01	with 1 bolt
14	S-0108-e	BOLT, MAIN AXLE CLAMP	01	M4 x 10 hex4 v3 main axle

\*Quantity needed to 1 cambering set.

## Group: FOLDING (F)

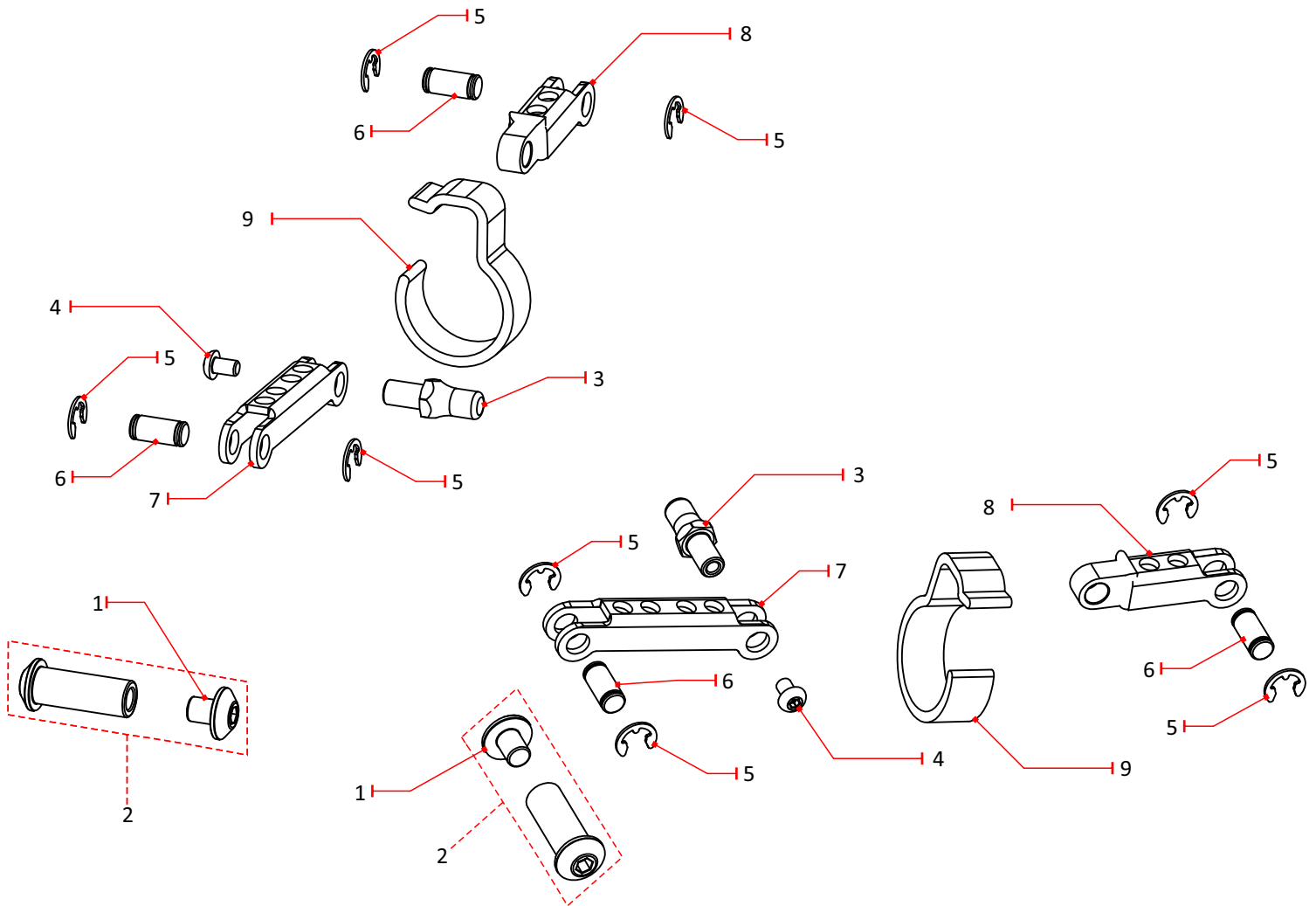

ITEM	PART #	PART NAME	QTY*	NOTE
1	S-0226	BOLT, FOLDING AXLE	02	M8X10X17
2	S-0225 - A/S-0226	AXLE SET, FOLDING	02	with bolt
3	P-0T251	KNOB, FOLDING	02	
4	BT-046	BOLT M5 x 8 x 9.5 (ISO 7380)	02	
5	C-0T06-B	LOCK WASHER DIN 6799 - 7	08	∅14 x ∅7 x 0.9t
6	P-0C244	AXLE, FOLDING LEVER	04	∅8 x 17.9
7	P-0C233	LEVER A, FOLDING	02	79 x 40 x 2.5
8	W-9C189	FOLDING LEVER B WELDED	02	58.2 x 16.7 x 13.2
9	P-0C243	LOCK CLAMPING, FOLDING T8h	02	41 x 58.8 x 15

\*Quantity needed to 1 folding set.

## Group: FRAME (F)

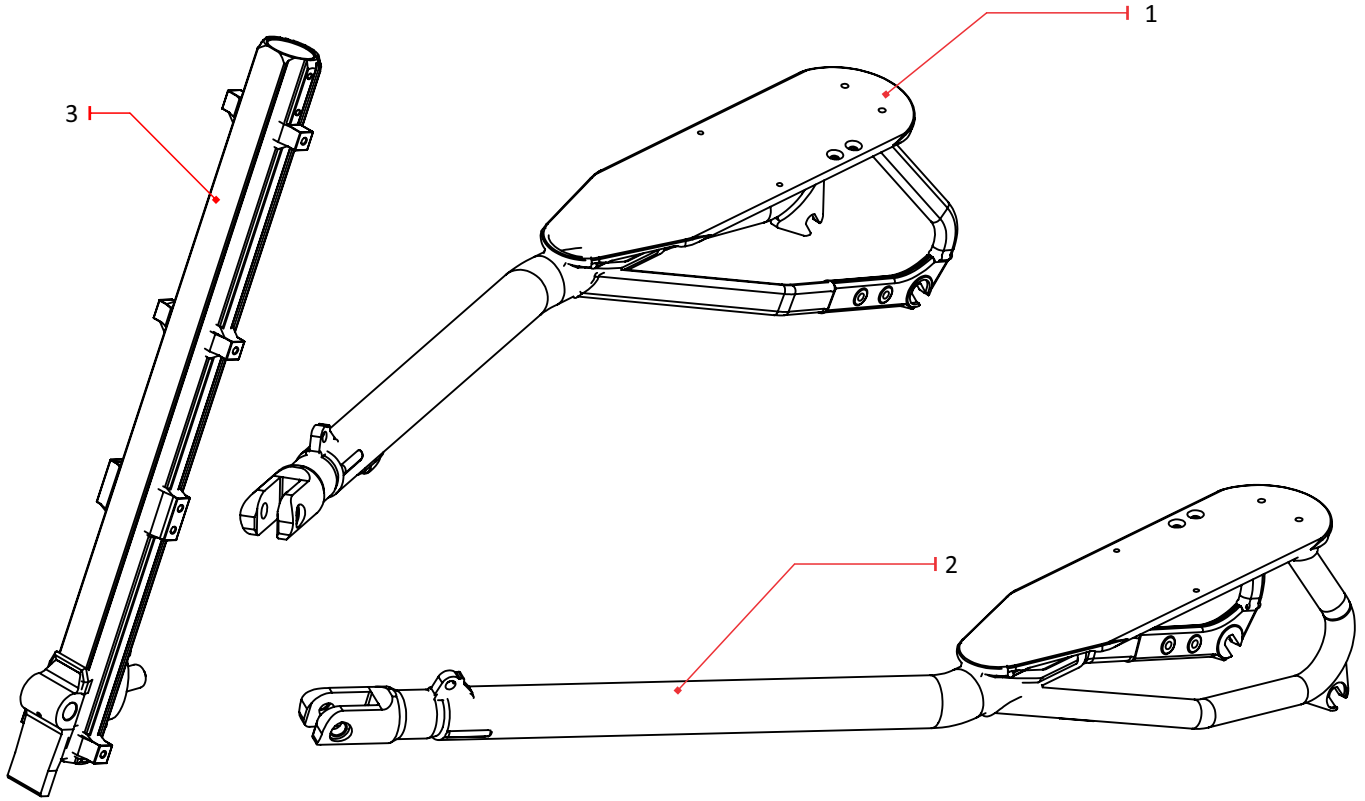

ITEM	PART #	PART NAME	QTY*	NOTE
1	W-9C05 - E	ARM BASIC, RH	01	
2	W-9C06 - E	ARM BASIC, LH	01	
3	W-9C20	FRONT STRUCTURE WELDED	01	

\*Quantity needed to 1 frame set.

## Group: WHEEL (W)

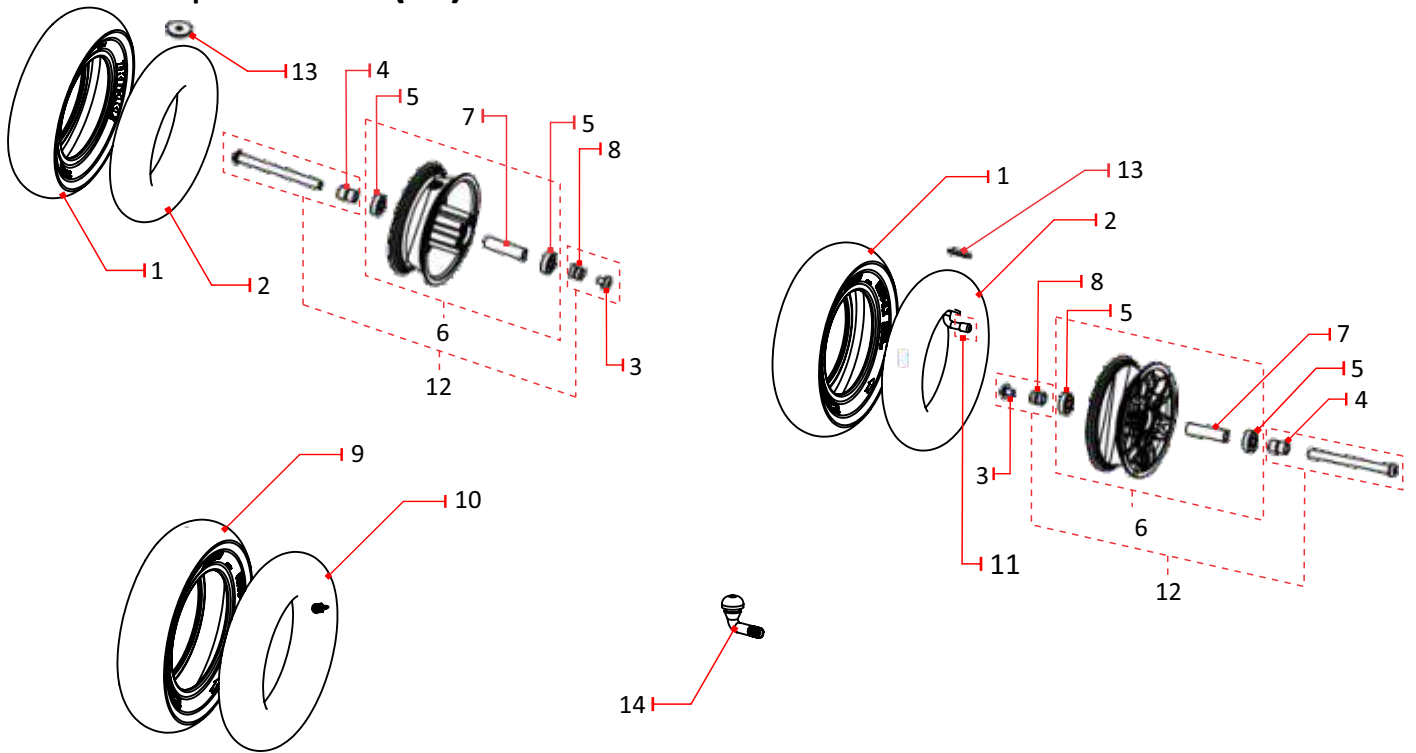

ITEM	PART #	PART NAME	QTY*	NOTE
1	S-0T57	TIRE 65/80-5.2 (9.5" x 2.5")	02	rear tire - heavy duty
2	S-0T78	INNER TUBE 5.2	02	rear tube
3	S-0226	BOLT, REAR WHEEL AXLE	02	M8 x 10 hex5
4	P-0T119	SPACER, WHEEL AXLE long	02	long 21.5 mm
5	C-0103	BEARING, WHEEL - ABEC 5	04	bearing 6000ZZ (10x26x8mm)
6	P-0T32/P-0T33/C-0103	RIM SET, 8.5 WHEEL RR	02	with bearings and spacer
7	P-0T33	SPACER, WHEEL BEARING	02	54.4 mm
8	P-0T118	SPACER, WHEEL AXLE short	02	short 13.5 mm
9	S-0T58	TIRE 65/85-6 (10.5" x 2.5")	01	front tire - heavy duty
10	S-0T79	INNER TUBE 6.0	01	front tube
11	C-0810	CAP, TIRE VALVE	03	
12	S-0T19/S-0226/P-0T118/P-0T119	AXLE SET, WHEEL	02	with bolt and 2 wheel spacers (21.5/13.5mm)
13	P-0T127	WASHER, INNER TUBE RUBBER	02	
14	P-9T51	AIR VALVE, SNAP IN (tubeless)	02	

\*Quantity needed to 1 wheel set.



**Group: ELECTRIC (E)**

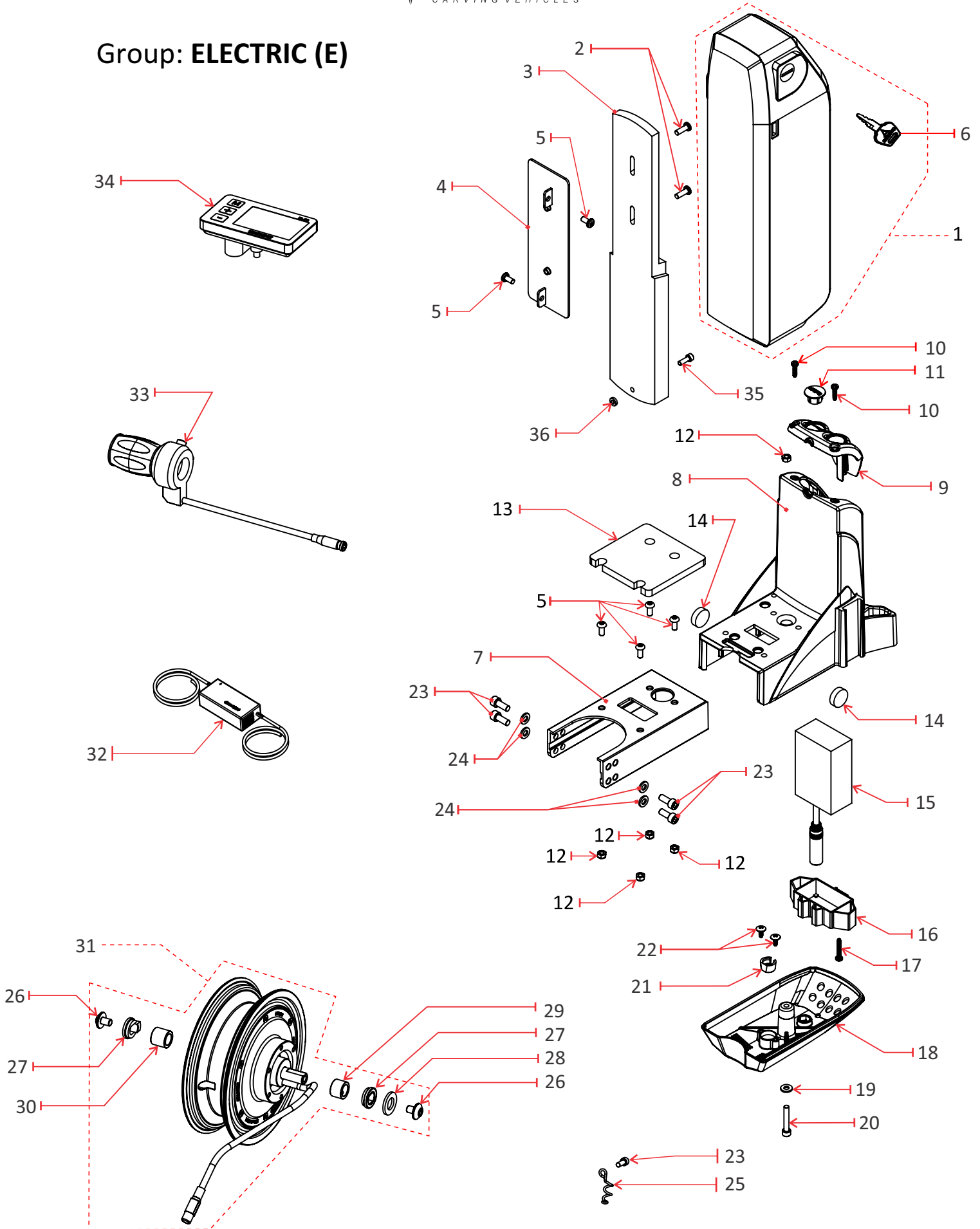

## Group: ELECTRIC (E)

ITEM	PART #	PART NAME	QTY*	NOTE
1	C-0C89	BATTERY, Li-ion 48V-11.25Ah/540Wh, T8h48V	01	YikLik KLC52H05S.082 (Li-ion Panasonic 48V-11,25Ah)
2	C-0C40	BOLT, BATTERY PLATE (M5 x 15 x 9)	02	M5 x 15 flat phillips
3	S-0C63	BRACKET, BATTERY	01	
4	W-9C152	BATTERY SUPPORT ADAPTER WELDED	01	
5	S-0C42-C	BOLT TORX SECURITY T25H, M5 x 10 x 9.5	02	M5 x 10 x 9.5
6	C-0C51	KEY, Blank Battery (no code)	01	
	C-0C51 - A	KEY, Copy Battery Key	01	copy made according to Battery Key code
7	P-0C164-A	SCISSOR, FRONT STRUCTURE	01	
8	P-0C01-B	BOX, CONTROLLER	01	
9	P-0C10	CAP, CONTROLLER BOX	01	
10	S-0C20	SCREW, CAP/CONTROLLER	02	SCREW TO PLASTICS 4 x 15 x 7
11	P-0855	PLUG	01	
12	C-0C12	NUT, M5 CONTR BOX	01	
13	P-0C235	PAD, BATTERY	01	
14	P-0C155	PAD, CUSHION Ø20 x 6t	02	
15	C-0C76	CONTROLLER, 48V Motor 17A	01	
16	P-0C233	CRATE, 1 CONTROLLER	01	
17	S-0C20-A	SCREW, CONTROLLER	01	SCREW TO PLASTICS 4 x 23 x 7
18	P-0C02-B	PAN, CONTROLLER BOX	01	
19	C-0C23	WASHER, CONTROLLER BOX PAN	01	
20	C-0C08	BOLT, PAN (M5X30X8.5) DIN 912	01	
21	P-0C159-A	SLEEVE, CONIC MOTOR CONNECTOR CLAMP	01	
22	S-0C38-A	SCREW, 4 x 10 x 10	02	
23	S-0T27	BOLT, M6 x 15 x 10 (DIN 912)	05	
24	S-0T97	WASHER, Ø12 x Ø6.4 x 1.6 (DIN 125 A)	04	
25	P-0C162	HOLDER, MOTOR CABLE	01	
26	S-0229	BOLT, M7 x 10 x 17	02	
27	S-0C36	WASHER, MOTOR AXLE LOCK	02	
28	C-0C70-A	WASHER, Ø13 x Ø24 x 2.5 (DIN 125-A)	01	
29	P-0C156-R	SPACER, MOTOR AXLE 12.6	01	
30	P-0C156-S	SPACER, MOTOR AXLE 16.1	01	
31	S-9T85/S-0229/S-0C36 C-0C70-A/P-0C156-R/P-0C156-S	MOTOR, 10" 48V-350W	01	long cable T8h
32	C-9C32 - A	CHARGER, Li-ion 100V-240V 48V-3.5A - T8h	01	spec power cord standard (USA, EU, UK)
33	C-0T16	THROTTLE SET, 48V SPEED (180mm)	01	THROTTLE HALF GRIP HALL SENSOR 48V (connector JULET - 5pin MALE green)
34	S-0T69-A/P-0T255/S-0C20	DISPLAY, LCD EL-X3	01	with support and bolts
35	C-0C05	BOLT M5 x 15 x 8.5 (DIN 912)	01	M5 x 15 x 8.5 (DIN 912)
36	C-0123-A	WASHER Ø10 x Ø5.1 x 2.5t	01	Ø10 x Ø5.1 x 2.5t

\*Quantity needed to 1 electric set.

**Group: STEERING (S)**

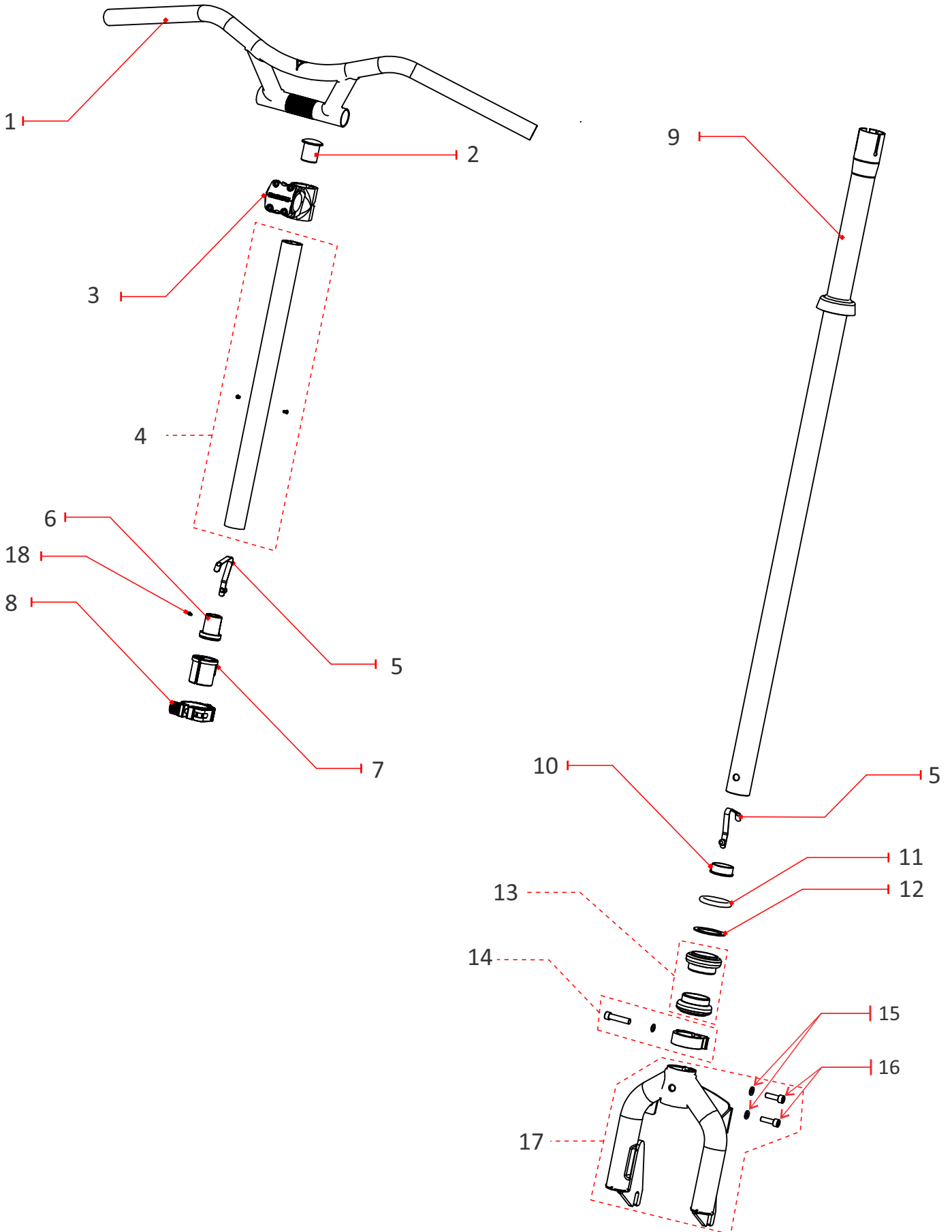

## Group: STEERING (S)

ITEM	PART #	PART NAME	QTY*	NOTE
1	W-9230-A	HANDLEBAR WELDED	01	
2	P-0854	PLUG, STEM POST TOP	01	
3	C-9C08	STEM, BOLTED	01	25.4 x 28 x 60 x 10
4	P-0C70/P-0869	POST, STEM	01	with 2 inserted pins
5	P-9828-d	PUSH PIN	02	
6	P-0859	PLUG, STEM POST GUIDE	01	
7	P-0818	BUSHING, QR GUIDE	01	
8	P-9C02	CLAMP SET, QR	01	
9	W-9C35	STEERING AXLE WELDED	01	
10	P-0C228	PLUG, STEERING AXLE	01	
11	C-0201	O'RING, HEADSET	01	
12	S-9006	WASHER, HEADSET	01	
13	S-9800	HEADSET, THREADLESS	01	
14	P-0C165/S-0202-A/P-0289	CLAMP SET, STEERING AXLE	01	with 1 bolt and 1 washer
15	P-0027	WASHER 11 x 6.4 x 1.6 (DIN 433)	02	
16	S-0808	BOLT, M6 x 20 x 10 (DIN 912)	02	
17	W-9O04-F/P-0027/S-0808	FRONT FORK SET	01	with 2 bolts and 2 washers
18	C-0C90	SET PIN #2 x 5/16" (Ø2 x 8mm)	01	#2 x 5/16" (Ø2 x 8mm)

\*Quantity needed to 1 steering set.

**Group: TRIM (T)**

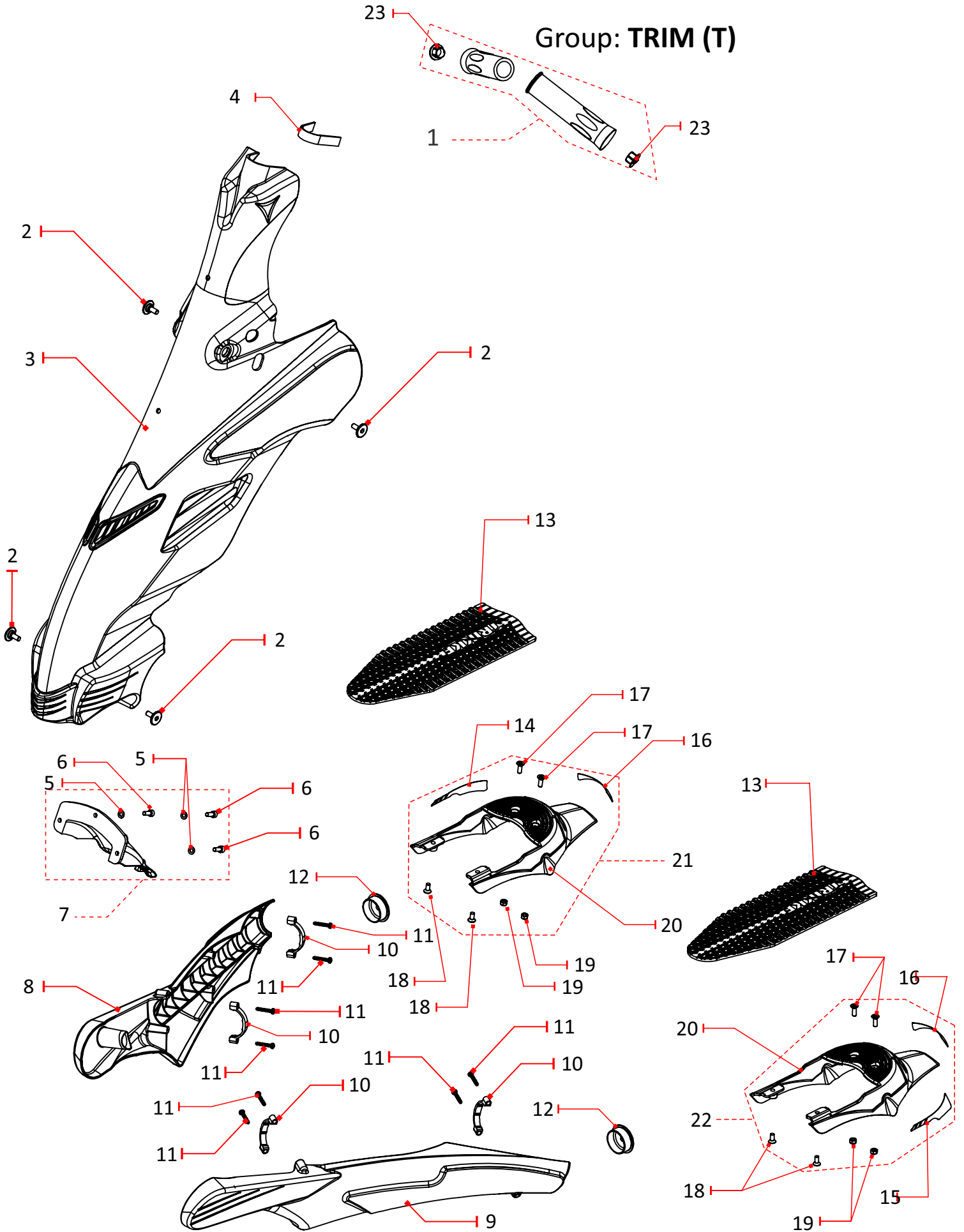

## Group: TRIM (T)

ITEM	PART #	PART NAME	QTY*	NOTE
1	C-0T16-R/C-0T16-L/P-0855	HAND GRIP PAIR, FOAM WITH LEATHER T8h	01	with 2 handlebar plugs
2	S-0C32	BOLT, fairing	04	M6 x 12 x 20 (1 piece)
3	P-0C16	FAIRING	01	
4	P-0C236	FELT, FAIRING	01	
5	S-0T55-A	WASHER, Ø10 x Ø5.3 x 1 (DIN 125 A)	03	
6	C-0C05-A	BOLT M5 x 12 x 8.5 (DIN 912)	03	
7	P-0T47-A/S-0T55-A/C-0C05-A	FRONT FENDER	01	with 3 bolts and 3 washers
8	P-0C18	SKIRT RH	01	
9	P-0C19	SKIRT LH	01	
10	P-0C20	BRACKET, SKIRT	04	
11	S-0C20-A	SCREW, 4 x 23 x 7	08	
12	P-0863	PLUG, ARM	02	
13	P-0C66-A	GRIP MAT, T8h	02	
14	P-0C71	REFLECTOR, REAR FENDER T8H RH	01	
15	P-0C72	REFLECTOR, REAR FENDER T8H LH	01	
16	P-0C68	REFLECTOR, REAR FENDER T8H REAR	02	
17	C-0130	BOLT, M5 x 15 (DIN 7991)	04	M5 x 15 hex4 counter sink
18	C-0130-A	BOLT, M5 x 12 (DIN 7991)	04	M5 x 12 hex4 counter sink
19	C-0812	NUT, M5 NYLOCK (DIN 985)	04	
20	P-0C67	FENDER, T8H REAR	02	
21	P-9C67	FENDER RH, T8H REAR	01	with reflectors, 4 bolts and 2 nuts
22	P-9C68	FENDER LH, T8H REAR	01	with reflectors, 4 bolts and 2 nuts
23	P-0855	PLUG, HANDLEBAR	02	

\*Quantity needed to 1 trim set.